

Serie PA 430.1



40 l/min
10,6 USGPM



40 bar
580 P.S.I.

03.7007.97.3 - VF Pompa a 3 membrane-pistone semidrauliche.
Versioni disponibili: "VF": standard 3 fori.

Pompe à 3 pistons-membranes semi-hydrauliques. Versions disponibles: "VF": Arbre standard avec 3 trous.

Bomba de 3 membranas-pistón semi-hidráulicas. Versiones disponibles: "VF": Cigüeñal estándar 3 agujeros.

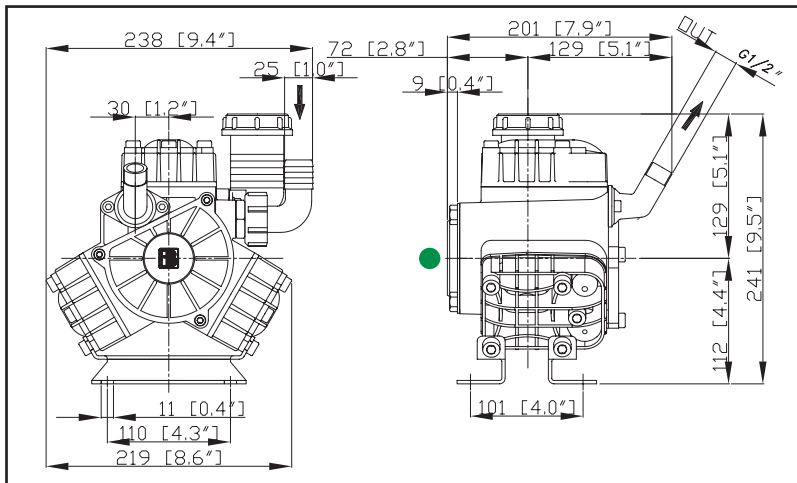

Optional Option Opción



Caratteristiche tecniche
Caractéristiques techniques
Características técnicas

g/min; t/min; rev./min.		g/min	R.P.M.	650	650
Potenza - Puissance - Potencia		KW	HP	2,8	3,8
Peso - Poids - Peso		Kg	lb	7,8	17
Dislivello aspirazione	MAX	mt	ft	1,5	4,9
Pression négative	Servizio discontinuo Emploi discontinu - Servicio discontinuo	mt	ft	3	9,8
Presión negativa					
Ø Aspirazione - Aspiration - Aspiración		mm	in	25	1"
Ø Mandata - Refoulement - Presión		mm	in	G.1/2	G.1/2
Max. Temperatura - Température - Temperatura		°C	°F	60	140
Tipo olio - Type huile - Tipo aceite		SAE	W	SAE 30	30 W
Capacità olio - Capacité huile - Capacidad aceite		lt	U.S.G.	0,6	0,16

TABELLA RENDIMENTI - TABLEAU DES PERFORMANCES
TABLA DE RENDIMIENTOS

g/min; t/min; rev./min.	500		550		600		650	
	L/min USGPM	KW HP	L/min USGPM	KW HP	L/min USGPM	KW HP	L/min USGPM	KW HP
BAR								
P.S.I.								
2	30,8	0,1	33,8	0,1	36,9	0,1	40,0	0,2
29	8,1	0,2	8,9	0,2	9,8	0,2	10,6	0,2
20	28,5	1,1	31,3	1,2	34,2	1,3	37,0	1,5
290	7,5	1,5	8,3	1,6	9,0	1,8	9,8	1,9
30	28,1	1,7	30,9	1,8	33,7	2,0	36,5	2,2
435	7,4	2,2	8,2	2,4	8,9	2,7	9,6	2,9
40	27,7	2,2	30,5	2,4	33,2	2,6	36,0	2,8
580	7,3	2,9	8,0	3,2	8,8	3,5	9,5	3,8



ALBERO POMPA • ARBRE POMPE • CIGÜEÑAL BOMBA



POST. • ARRIERE • POSTERIOR

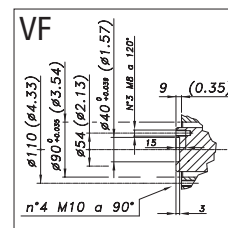

Pag. 34

BERTOLINI
pumps

Serie PA