

DIMENSIONI D'INGOMBRO - OVERALL DIMENSIONS

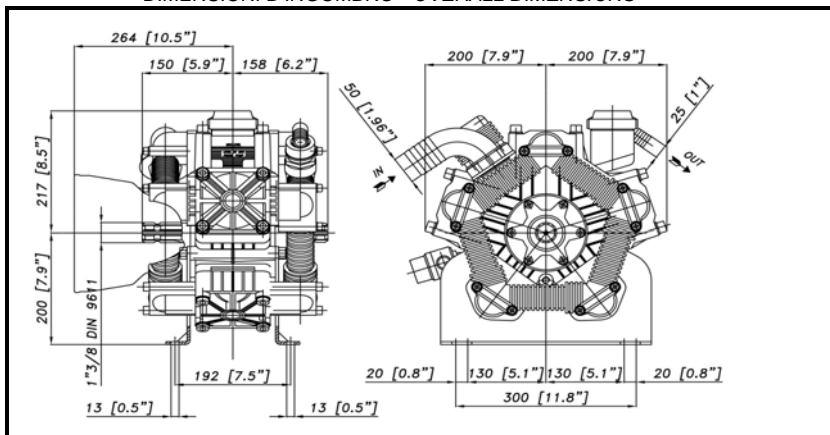

ALBERO POMPA - PUMP SHAFT

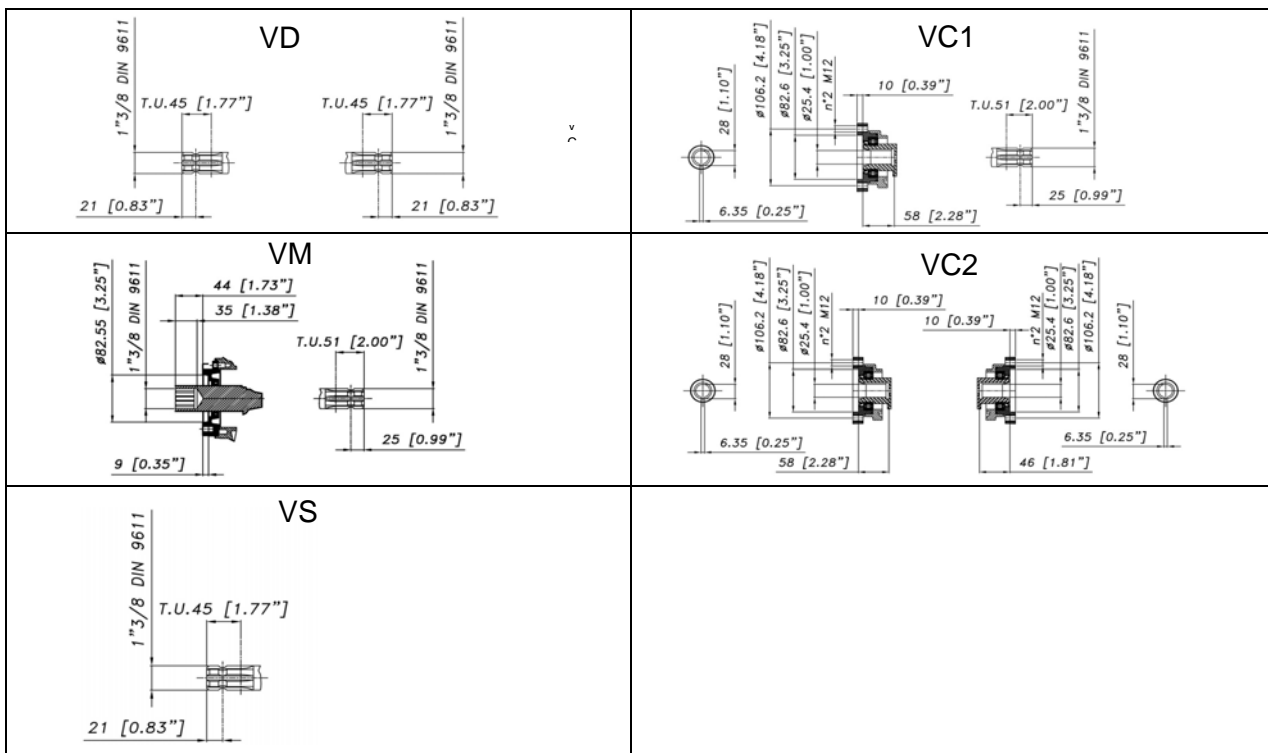

COPIA DI SERRAGGIO - TORQUE CHART



CODICE - CODE	Q.TY	POS	N.m	Lbr.ft
62.9811.97.3	5	9	25	18.4
85.2576.00.2	2	40	5 (LOXEAL 24-18)	3.7 (LOXEAL 24-18)
86.2684.50.2	2	18	8	5.9
86.3694.65.2	1	55	40	29.5
86.2562.20.2	6	46	22	16.3
86.2684.00.2	2	64	22	16.3
86.2985.50.2	20	31	10	7.4
86.4139.10.2	3	53	40	29.5
86.4068.50.2	20	8	40	29.5
83.8260.20.2	20	83	10	7.4
81.4573.00.2	20	84	15	11
86.2852.00.2	4	91	10	7.4

Tolleranza di serraggio: 0/-10%
Tolerance on torque value: 0/-10%

INFORMAZIONI UTILI USEFUL INFORMATION



LUBRIFICANTE - LUBRICANT:				
OLIO MOTORE O SEMIDRAULICO SAE 30 MOTOR OIL OR SEMI-HYDRAULIC OIL SAE 30				
PRESSIONE ACCUMULATORE ACCUMULATOR PRESSURE				
PRESSIONE DI LAVORO - OPERATING PRESSURE	2 ÷ 5	5÷10	10 ÷ 20	20 ÷ 50
ACCUMULATORE ACCUMULATOR	2	2 ÷ 5	5 ÷ 7	6 ÷ 8

KIT MEMBRANE - DIAPHRAGMS KIT

KIT	PRE-SET DURAMAX	PRE-SET DESMOPAN	VITON						PENTAX
POSIZIONE ESPLOSO POSITION NUMBER	1 3	1 3	1	3	29	32	5	38	1 3
QUANTITA' NEL KIT QUANTITIES INCLUDED	5 10	5 10	5	10	1	1	5	10	5 10

*.3: per pompe con calotta accumulatore in alluminio/for pumps with aluminum ballaster cover
*.A: per pompe con calotta accumulatore in polipropilene/for pumps with polypropylene ballaster cover

KIT POMPA/KIT VALVOLE - PUMP KIT/VALVES KIT

KIT	KIT POMPA VD VD PUMP KIT	KIT POMPA VC1/VM VC1/VM PUMP KIT	KIT POMPA VC2 VC2 PUMP KIT	VALVOLE 303 VALVES	VALVOLE 316 VALVES
POSIZIONE ESPLOSO POSITION NUMBER	3 38 48 49 5	38 3 5 48 69 49	38 3 5 48 69 74	2 3 5	2 3 5
QUANTITA' NEL KIT QUANTITIES INCLUDED	10 10 1 2 5	10 10 5 1 1 1	10 10 5 1 1 1	10 10 5	10 10 5

POLY 2210 VD (1"3/8 M-M)

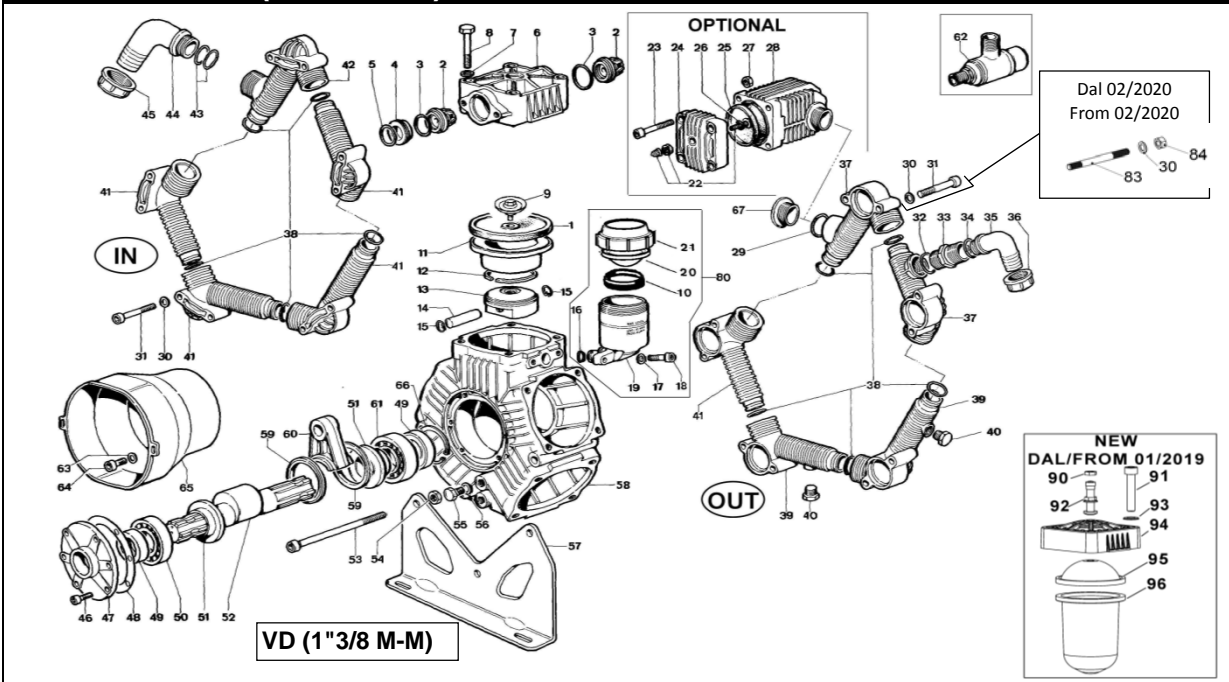

VERSIONI			
VS (1"3/8 M)	VM (1"3/8 M-F)	VC1 (1"3/8 - D.1" M-F) VC1 (1"3/8 - D.25mm M-F)	VC2 (D.1" F-F) VC2 (D.25mm F-F)

POS.	CODICE PART NO. REF.	DENOMINAZIONE - DESCRIPTION - DESCRIPTION	Q.TY	POS.	CODICE PART NO. REF.	DENOMINAZIONE - DESCRIPTION - DESCRIPTION	Q.TY
1	62.0040.00.ADS	PRE-SET DURAMAX PISTON DIAPHRAGM (STD)	5	44	84.0610.00.2	90° ELBOW CONNECTOR DIA.50-1,96"	1
1	62.0040.00.A	PRE-SET DESMOPAN PISTON DIAPHRAGM (OPT)	5	44	84.1643.00.2	STRAIGHT CONNECTOR DIA.50-1,96" (OPT)	1
1	62.0040.33.2	VITON PISTON DIAPHRAGM (OPT)	5	45	82.0120.00.2	WING NUT G.2"	1
1	62.0040.36.2	HPS PISTON DIAPHRAGM (OPT)	5	46	86.2562.20.2	BOLT M8x20 UNI5931	6
2	28.9905.97.3	S.S. AISI 316 VALVE ASSY (STD.)	10	47	14.0011.09.2	COVER	1
2	28.9809.97.3	S.S. AISI 303 VALVE ASSY (OPT.)	10	48	91.0110.72.2	COVER GASKET	1
3	80.3314.50.2	O-RING 4,5x40 VITON	10	49	80.2143.10.2	OIL SEAL DIA.35x52x7	2
4	28.0229.32.2	VALVE ASSY SPACER	5	50	81.2876.00.2	BEARING DIA.35x100x25	1
5	80.3209.30.2	O-RING 2,62x42,52 VITON	5	51	14.0016.01.2	SHAFT SPACER	2
6	62.0025.32.2	HEAD	5	52	14.0009.26.2	CRANKSHAFT "VD" VERSION	1
7	84.3845.00.2	WASHER DIA.12,2x21x2,5	20	53	86.4139.10.2	BOLT M12x160	3
8	86.4068.50.2	BOLT M12x75 UNI5931	20	54	81.4689.30.2	M12 UNI 5589	3
9	62.9811.97.3	KIT BOLT/DISK S.S.	5	55	86.3694.65.2	BOLT M12x20 UNI5931	1
10	14.0116.32.2	SPACER	1	56	82.4079.00.2	GASKET DIA.13,2x17x1 COPPER	1
11	62.0019.01.2	PISTON SLEEVE	5	57	55.0003.61.2	MOUNTING RAIL	2
12	81.8540.00.2	PISTON RING DIA.78	5	58	55.0001.09.2	CRANKCASE	1
13	62.0018.09.2	PISTON DIA.78	5	59	14.0015.76.2	CONROD RING	2
14	85.2006.70.2	PISTON PIN DIA.15	5	60	55.0005.11.2	CONROD	5
15	80.0021.00.2	RING DIA.15	10	61	81.2867.00.2	BEARING DIA.35x80x21	1
16	80.3180.00.2	O-RING 2,62x15,08	1	62	24.3115.97.3	SAFETY VALVE 15bar (OPT)	1
17	84.3685.40.2	WASHER DIA.8,2x15x1,5	2	63	84.3697.00.2	WASHER DIA.8,5x24x2	2
18	86.2684.50.2	BOLT M8x25 UNI5931	2	64	86.2684.00.2	BOLT M8x25 UNI5931	2
19	55.0004.32.2	OIL FILLER	1	65	31.1482.32.2	PLAIN SAFETY CONE L=180 (OPT)	1
20	41.0017.31.2	DIAPHRAGM OIL FILLER	1	65	31.1468.32.2	PLAIN SAFETY CONE L=135 (OPT)	1
21	28.0144.32.2	OIL FILLER CAP	1	66	80.1369.00.2	RING DIA.52	1
22	86.1608.50.2	AIR VALVE (BEFORE 01-19)	1	67	85.2720.00.2	CAP G.1"	1
23	86.2752.10.2	BOLT M8x35 UNI5931 (BEFORE 01-19)	4	68	14.0037.07.2	CAP	1
24	11.0004.09.2	BALLASTER COVER (BEFORE 01-19)	1	69	80.2191.10.2	OIL SEAL DIA.45x62x7	1
25	23.0041.31.2	BALLASTER DIAPHRAGM (BEFORE 01-19)	1	70	81.2945.00.2	BEARING DIA.45x100x25	1
25	23.0041.33.2	VITON BALL. DIAPH. (OPT.) (BEFORE 01-19)	1	71	14.0038.61.2	CIRCLIP DIA.45	1
23	23.0041.36.2	HPS BALL. DIAPH. (OPT.) (BEFORE 01-19)	1	72	14.0041.26.2	CRANKSHAFT "VC1" D.1"	1
26	80.3213.00.2	O-RING 3,0x6	1	72	14.0041.26.2A	CRANKSHAFT "VC1" D.25mm	1
27	81.4574.50.2	NUT M8 UNI5588	4	72	14.0040.26.2	CRANKSHAFT "VM" VERSION	1
28	27.0035.32.2	DAMPER BODY	1	73	14.0111.07.2	HODRAULIC MOTOR FLANGE	1
29	80.3206.50.2	O-RING 2,62x28,25 VITON	1	74	80.2178.10.2	OIL SEAL DIA.40x52x17	1
30	84.3685.40.2	WASHER DIA.8,2x15x1,5	20	75	81.2900.00.2	BEARING DIA.40x80x18	1
31	86.2985.50.2	BOLT M8x70 UNI5931 (BEFORE 02/2020)	20	77	14.0110.61.2	SPACER	1
32	80.3219.15.2	O-RING 3,0x30 VITON	1	78	14.0109.26.2	CRANKSHAFT "VC2" D.1"	1
33	83.5089.00.2	NIPPLES G.1"-G.1"1/4	1	78	14.0109.26.2A	CRANKSHAFT "VC2" D.25mm	1
34	80.3219.05.2	O-RING 3,0x25 VITON	1	79	86.2684.00.2	BOLT M8x25 UNI 5931	4
35	84.0542.40.2	90° ELBOW CONNECTOR DIA.25-1"	1	80	55.9817.97.3	OIL FILLER KIT	1
35	84.1608.40.2	STRAIGHT CONNECTOR DIA.25-1" (OPT.)	1	81	80.2099.60.2	CAP 52X7	1
35	84.0560.00.2	90° ELBOW CONNECTOR DIA.30-1,18" (OPT.)	1	82	14.0118.26.2	CRANKSHAFT "VS" VERSION	1
35	84.1620.50.2	STRAIGHT CONNECTOR DIA.30-1,18" (OPT.)	1	83	83.8260.20.2	STUD M8 (FROM 02/2020)	20
36	82.0067.50.2	WING NUT G.1"1/4	1	84	81.4573.00.2	NUT M8 (FROM 02/2020)	20
37	55.0008.32.2	MANIFOLD PIPE G.1"	2	90	86.1611.00.2	AIR VALVE NUT (FROM 01-19)	1
38	80.3250.10.2	O-RING 3,53X31,34 VITON	10	91	86.2852.00.2	SCREW M8X45 (FROM 01-19)	4
39	55.0009.32.2	MANIFOLD PIPE G.3/8"	2	92	86.1609.00.2	AIR VALVE (FROM 01-19)	1
40	85.2577.10.2	CAP G.3/8 + OR	2	93	84.3685.40.2	WASHER D.8,4x15x1,5 (FROM 01-19)	4
41	55.0006.32.2	MANIFOLD PIPE	5	94	11.0183.32.2	BALLASTER COVER (FROM 01-19)	1
42	55.0007.32.2	MANIFOLD PIPE G.2"	1	95	10.0041.31.2	SUP. BALLASTER DIAPHRAGM (FROM 01-19)	1
43	80.3209.15.2	O-RING 2,62x40,95 VITON	2	96	23.0094.31.2	INF.BALLASTER DIAPHRAGM (FROM 01-19)	1